

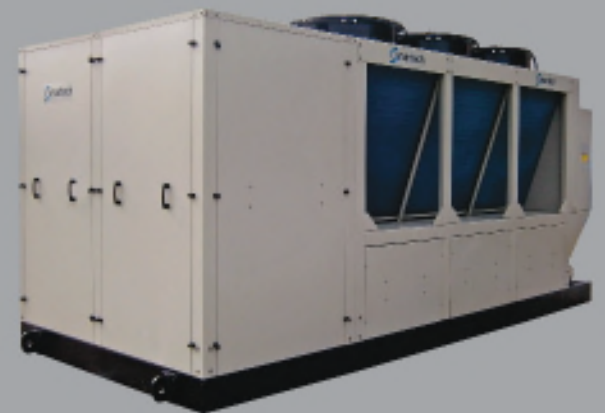

Air Cooled Screw Chillers Model SSCD



- Highlighted options.....
- Integral Pump/tanks
 - Copper condenser fins
 - Stainless steel shell & tube evaporator
 - Stainless steel electrical enclosure



Super efficient, Ultra-quiet operation



Custom Low Temperature, Explosionproof Designs available

SMARTECH AMERICA | 1118 FIRST STREET E
 www.SMARTCOOLINGPRODUCTS.COM | HUMBLE TX 77338
 www.SMARTECHAMERICA.COM | 281.540.2805

Specifications in this catalogue are subject to change without notice in order that SMARTECH may bring the latest innovations to their customer.

*Smartwise Innovations...
Towards Green, Quality & Reliability Solutions*





■ Introduction

This series of Screw Compressors Air Cooled Package Chillers were developed by a group of industry engineers, each of them with over 20 years of experience in the design, manufacturing, installation and service of electric chillers, packaged air-conditioners, split air-conditioners, fancoils, handling units, and related products.

- We are fully committed to innovative design, new and advance technology, value engineering and to provide expert personalized service to architects, consulting engineers, developers, building owners and contractors.
- Our ability and courage to utilize and adopt latest technology, combined with fullest personalized assistance, has enabled the company to provide architects, consultants and developers various customized solutions to their various demanding application requirements.
- Smartech has the unique expertise and experience to custom design and fabricate equipment for installations in marine and corrosive environments, explosive and hazardous environments, low noise environments and any other special application needs.
- All units meet or exceed ASHRAE 90.1 minimum energy efficiency requirements.
- Units meet UL electrical requirements and ETL listed (ETL may not apply to all models).
- Only used with ECO-FRIENDLY HFC type refrigerants.

■ Nomenclature

SSCD	150	6	A	R7
SMARTECH Chiller Screw Compressor DX Evaporator	Nominal Cooling Tons	60Hz	Air Cooled Type	R7 - R407C

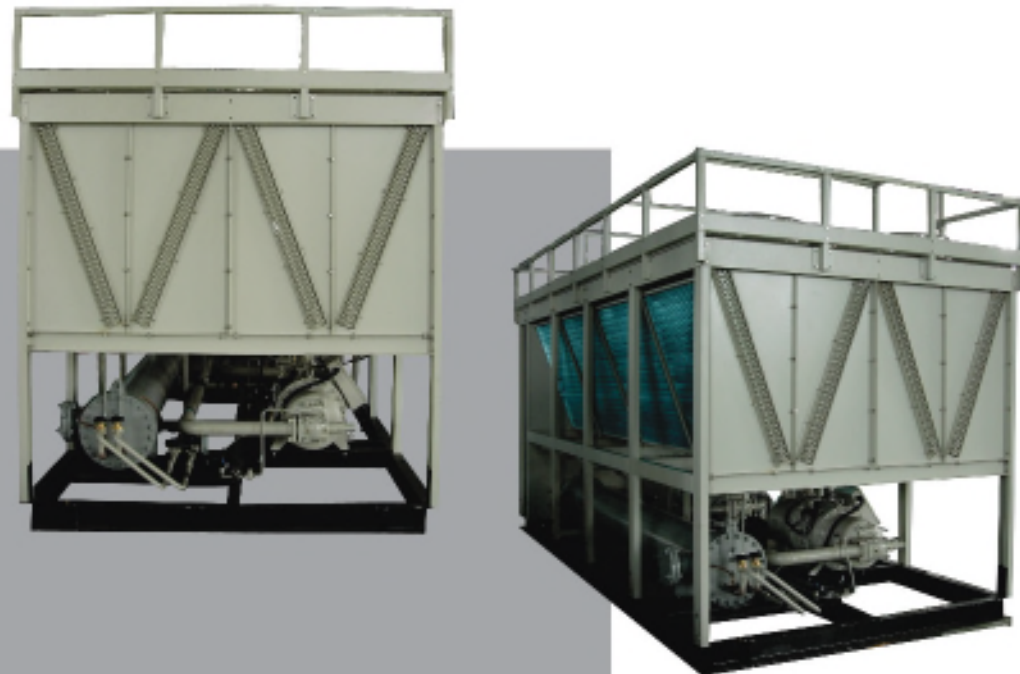

DIMENSION DATA

SSCD 250-6 AR7

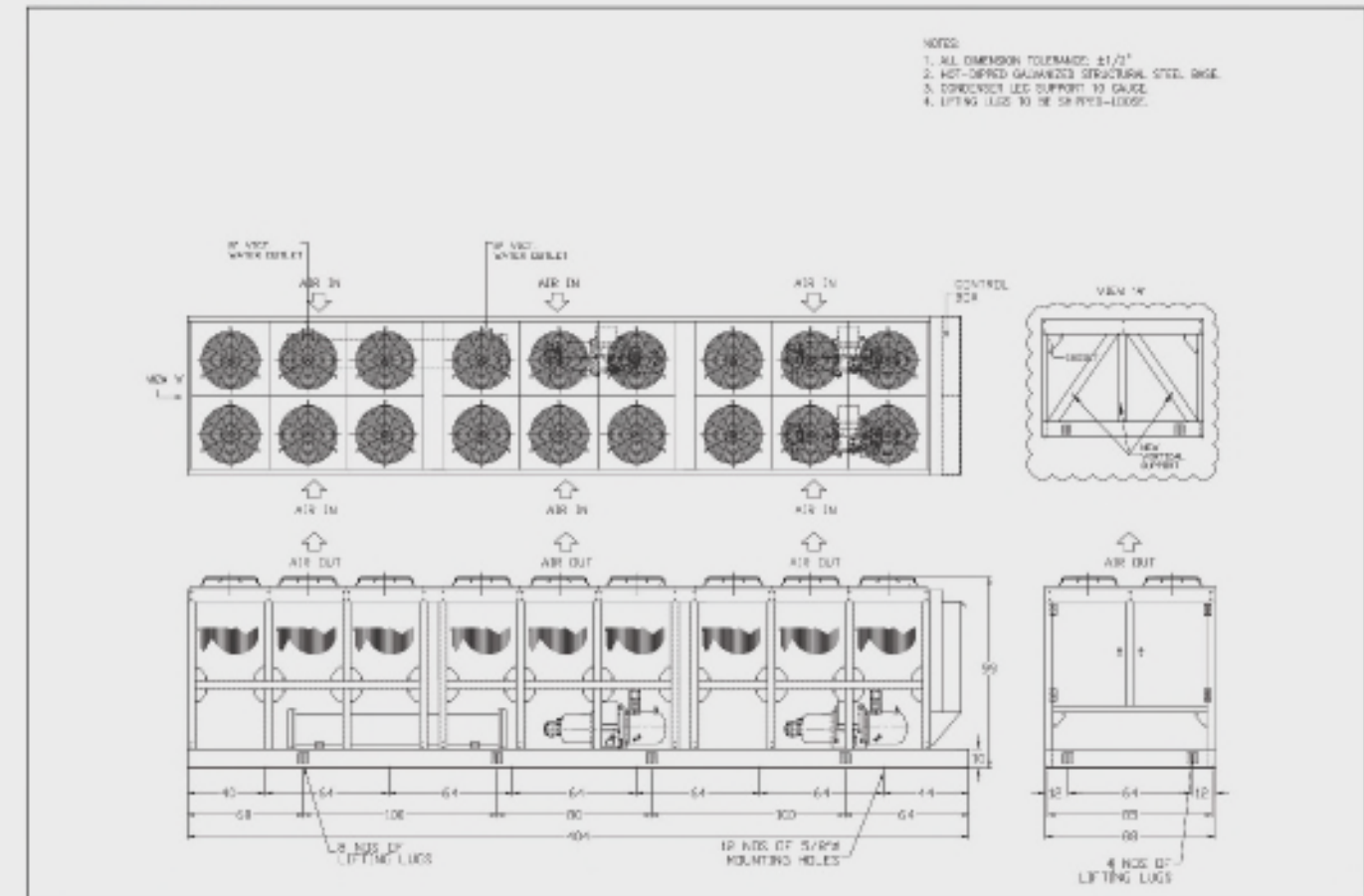

SSCD 320-6 AR7

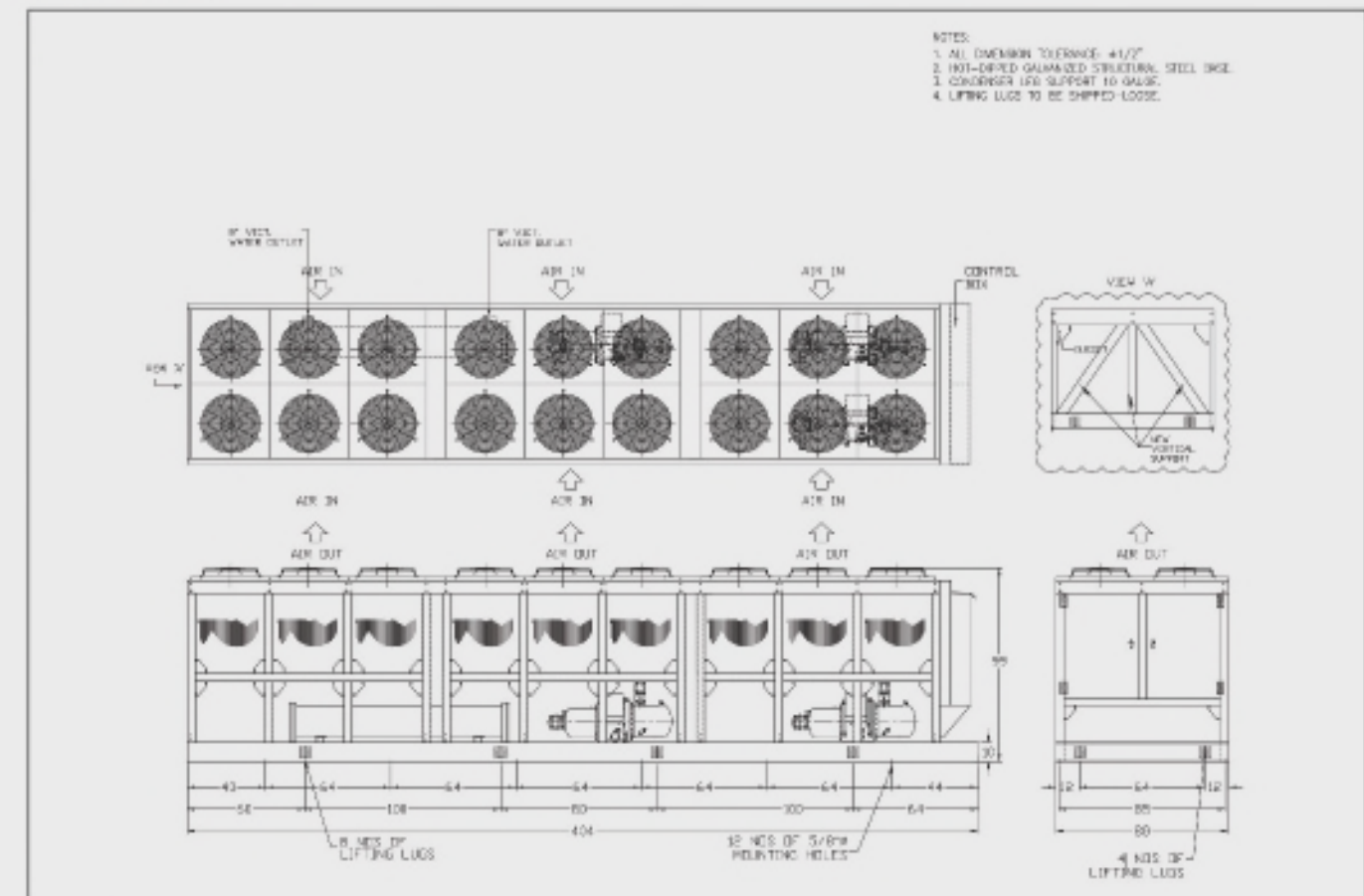

Note: All dimensions are in inches.
 All dimensions tolerance ±1/2".

DIMENSION DATA

SSCD 150-6 AR7

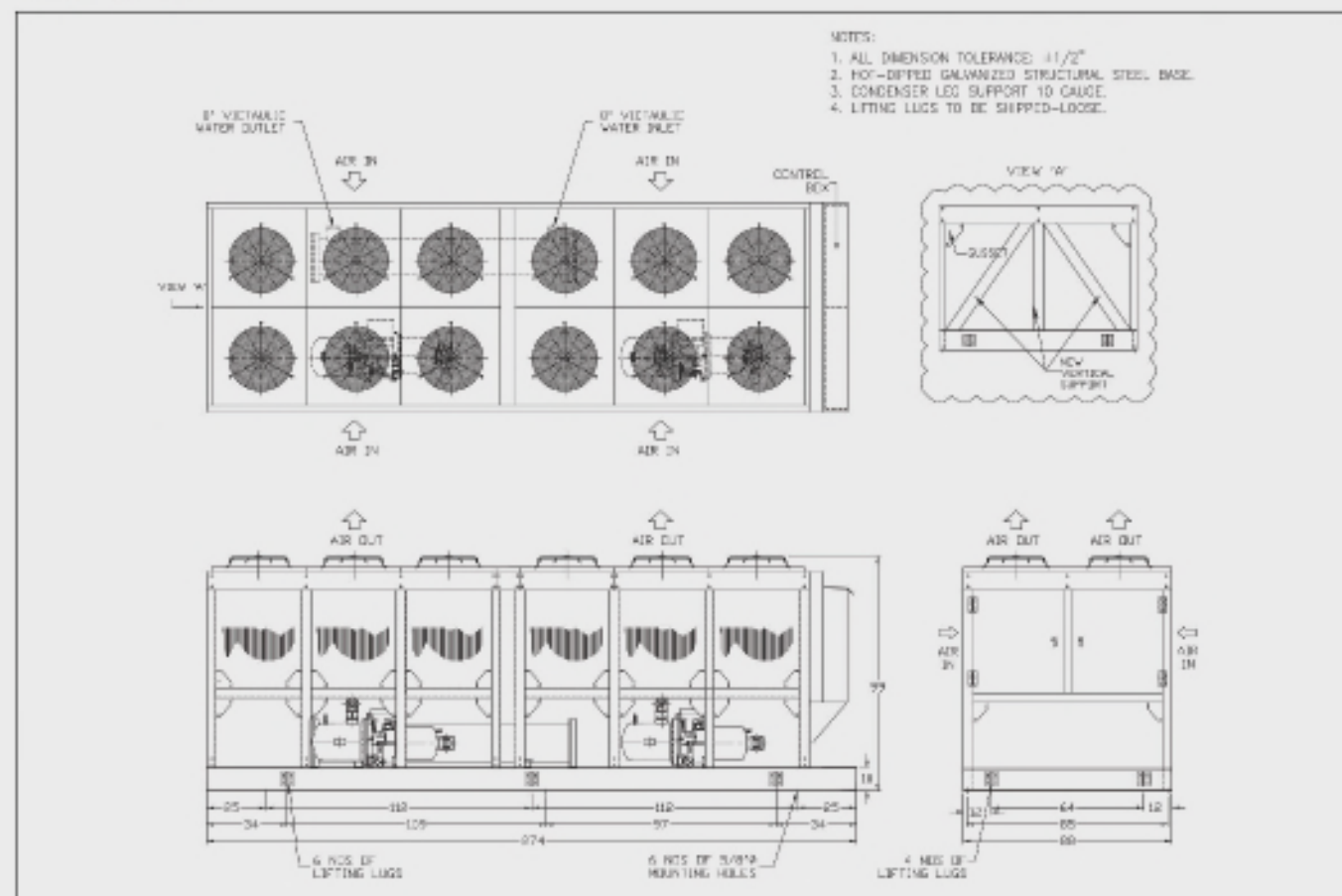

SSCD 210-6 AR7

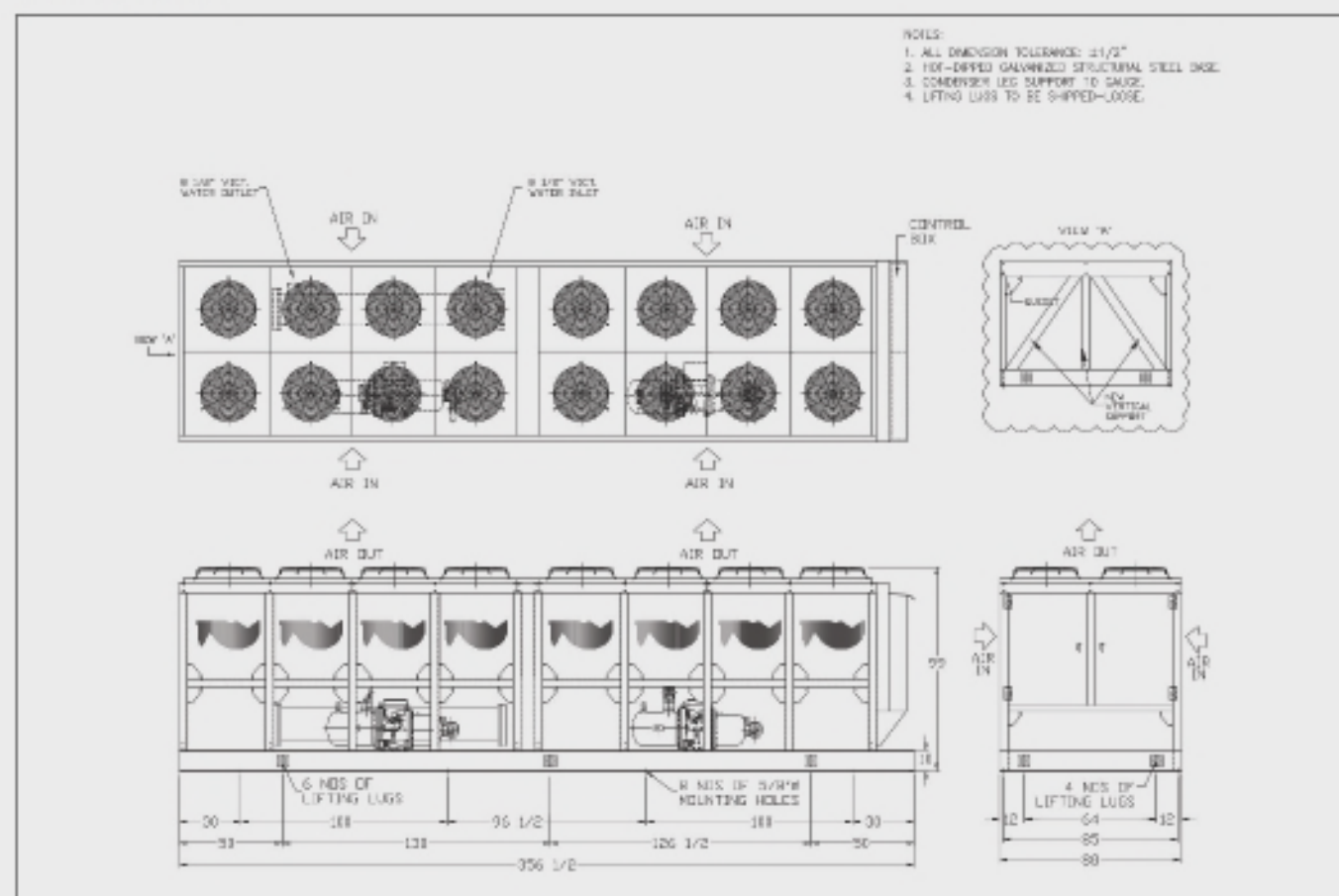

Note: All dimensions are in inches.
All dimensions tolerance $\pm 1/2"$.



SCREW COMPRESSORS AIR COOLED PACKAGE CHILLERS

GENERAL DESCRIPTION

These Air Cooled Screw Chillers are designed and manufactured to ensure efficient and reliable performance and to provide an economical system of air conditioning for commercial and industrial buildings. The air-cooled screw chillers can also be suitably piped and connected to provide chilled water or cold brine solution for process cooling purpose.

Each air-cooled screw chiller consists of an outdoor weatherproof casing constructed from heavy gauge galvanized steel coated with oven-baked epoxy polyester paint; two or multiple screw compressors with minimum two independent refrigerant circuits; a large surface area Copper tubes-Aluminium fins condenser coil for efficient heat transfer; a shell and tubes type evaporator; two or multiple axial propeller fans with direct drive inductions motors; factory packaged and prewired power and control panel; and a microprocessor based controller for capacity steps modulation and safety protections.

The air-cooled screw chillers are suitable for outdoor installation with free and unducted condenser fans air discharge.

APPLICATIONS SERVED

Industrial Process Cooling

Although the term industrial lends one to think tough & rugged, industrial process applications can actually be quite sensitive. Many of these applications need tight temperature control to maintain their quality of product. We, at Smart Family, understand these needs and realize that your process is your lifeblood. Accurate temperature control and 24/7 reliability are our top priorities. This list show some common process cooling applications:

- Plastics processing
- Injection mold cooling
- Extrusion cooling
- Laser cooling
- Welding machine cooling
- Metal die-casting cooling
- Metal plating / anodizing cooling
- Engine dynamometer testing cooling
- Dry cleaning cooling
- Oil cooling

Food Processing Cooling

Food processing can be some of the most critical cooling applications due to their use of meats & poultry. In dealing with food, in general, temperature control is paramount. If your chiller does not hold temperature, you lose product. We have experience in the various food processing cooling applications and can help you find a solution to yours.

Here are just a few applications we have handled previously:

- Bakery cooling
- Batch cooling
- Brine / Marinade cooling
- Vacuum meat tumbler / massager cooling
- Winery cooling
- Brewery cooling
- Ice cream / Slushy machine cooling

SCREW COMPRESSORS AIR COOLED PACKAGE CHILLERS *cont'd*

APPLICATIONS SERVED

Medical & Laboratory Cooling

Medical equipment is a high dollar investment. It deserves to be cooled by a dependable, specially designed chiller. Our chillers provide proven reliability to sustain operation and prevent damage from overheating. Several applications are listed below:

- M.R.I cooling
- Clean room air conditioning
- C.A.T. Scan cooling
- P.E.T Scan cooling
- Lab testing

Specialty applications

Have a special or custom application? No problem. Custom chiller applications are where we thrive. We are here to help. Some previous custom projects are:

- Ice Rink cooling
- Explosion proof chillers for all electrical area classifications
- Stainless steel frame, cabinet and control panel construction
- Ultra Low Sound requirement.

Standard options available to meet any customer requirement:

- Insulated stainless steel tanks from 50 - 5000 gallons
- Hydronic pump packages with process pumping and recirculating pump options
- Nema 4 flow switch or flow meters
- Alarm beacon with audible horn
- Waterside pressure relief bypass valve
- Process fluid inline separator
- Process fluid inline filter
- Extended compressor warranty
- Custom color paint to match any international color code
- High and low ambient operations options
- OSHA Approved Condenser Handrail system (Optional Ladder with Cage Assembly)
- Low temperature options available
- Explosion-proof options available

DIMENSION DATA

SSCD100-6 AR7

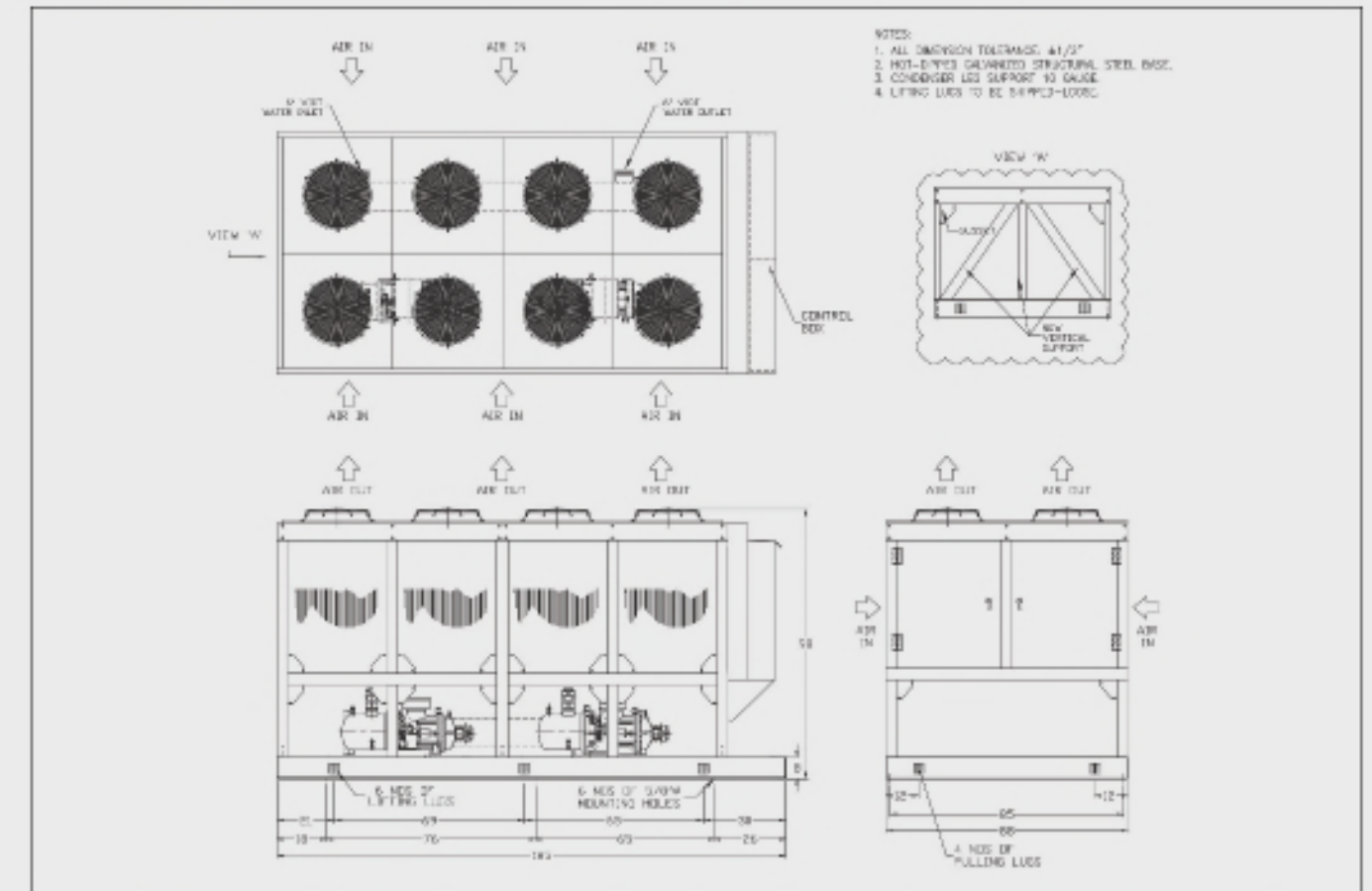

SSCD125-6 AR7

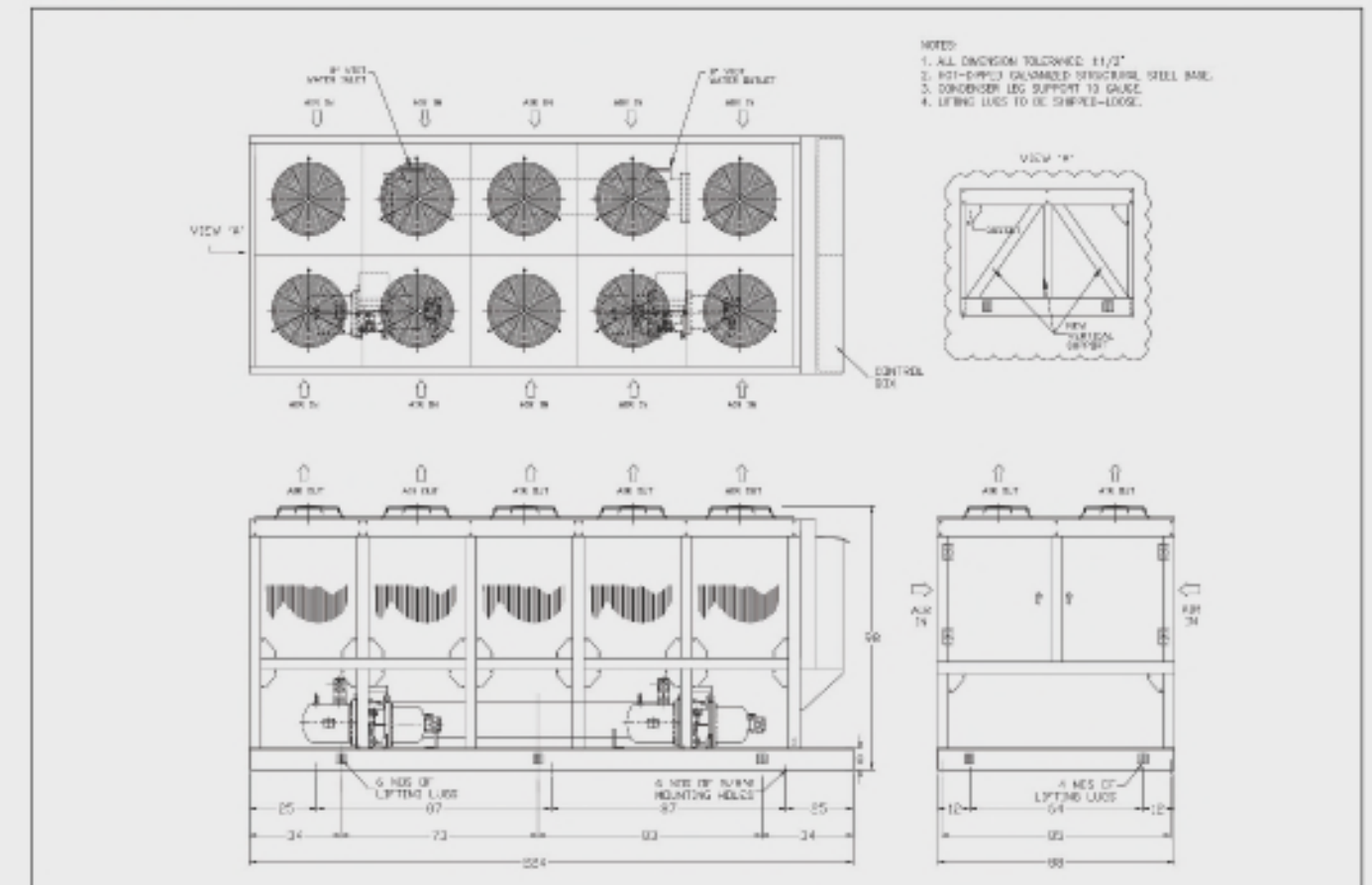

Note: All dimensions are in inches.
 All dimensions tolerance $\pm 1/2"$.

DIMENSION DATA

SSCD 60-6 AR7

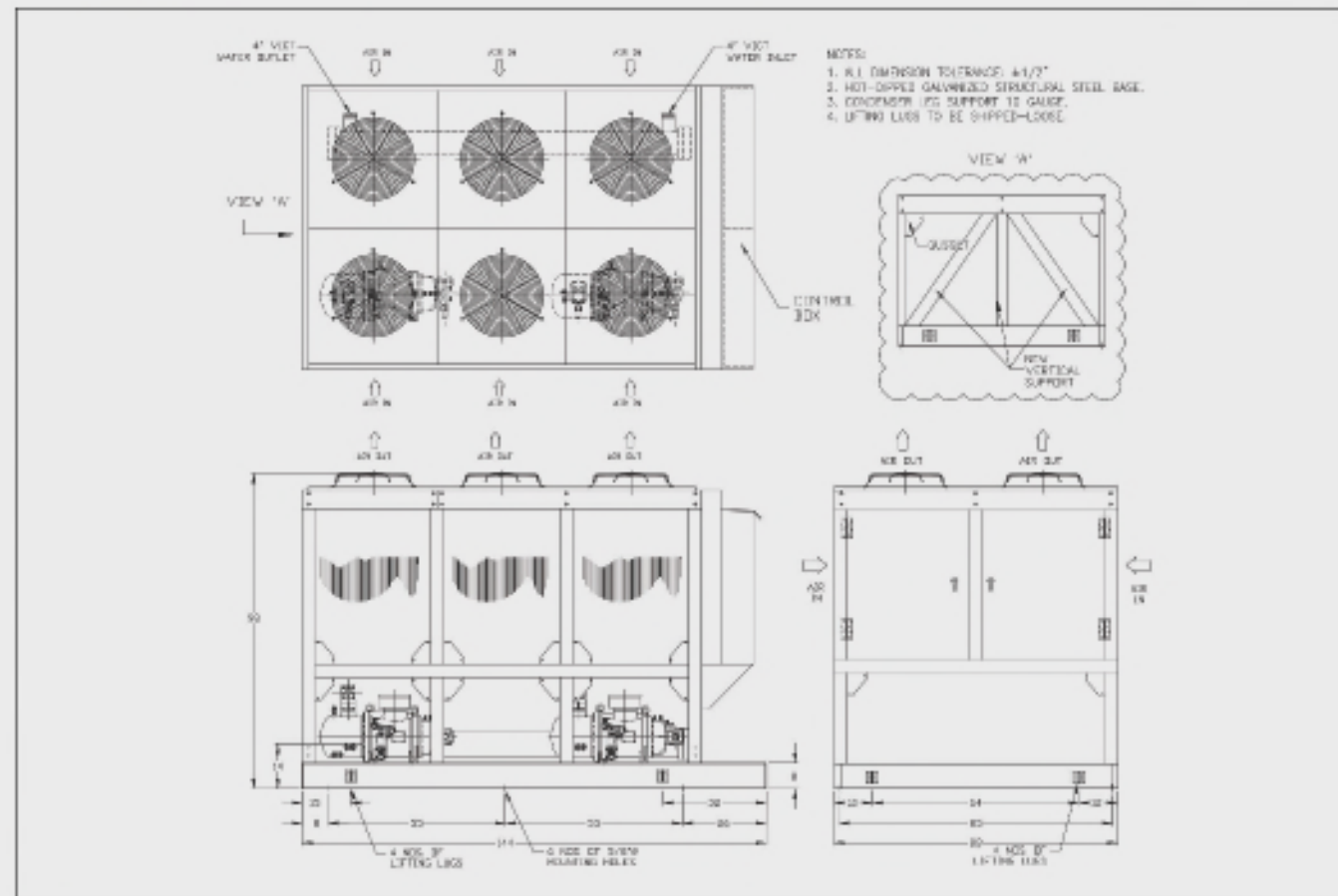

SSCD 80-6 AR7

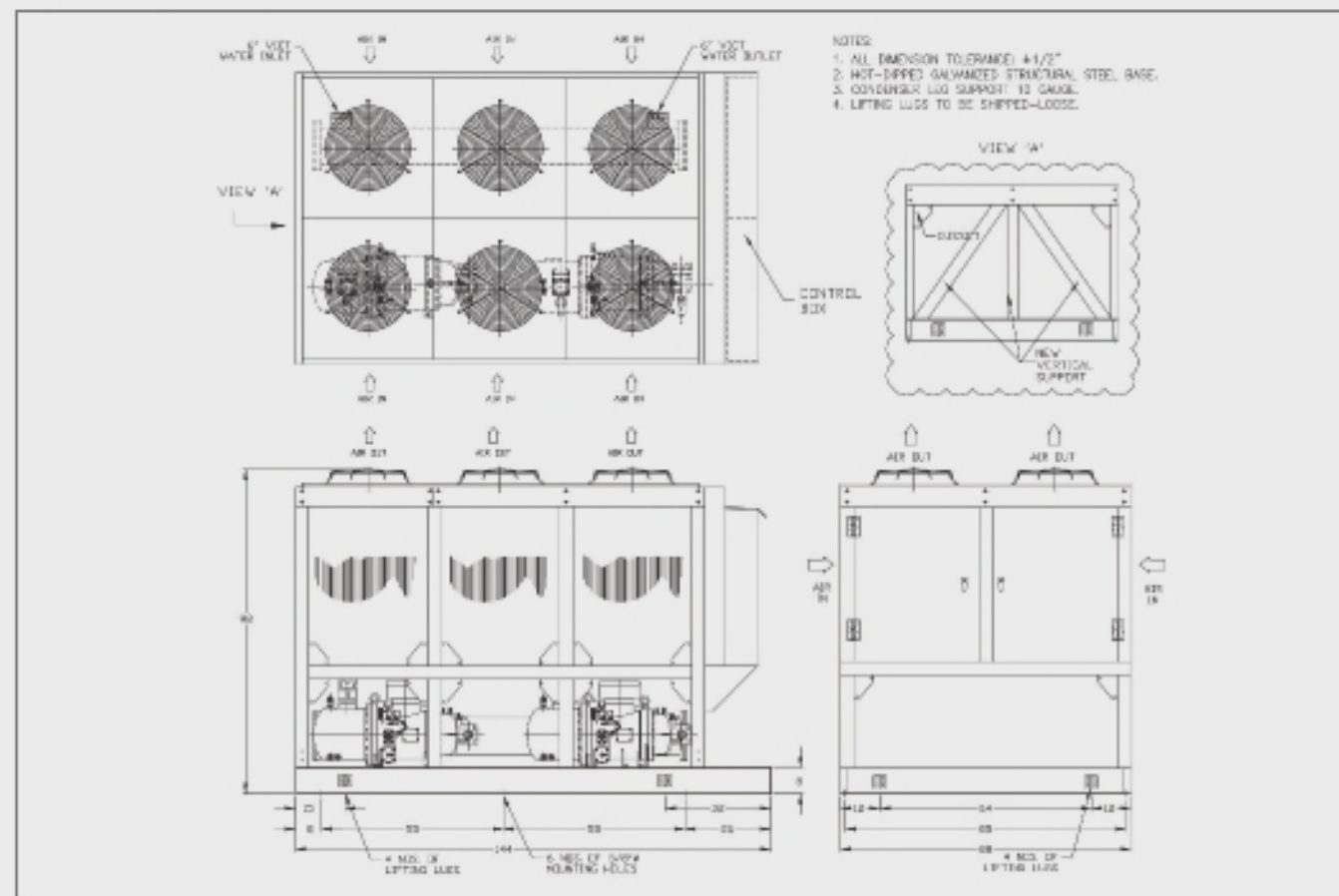

Note: All dimensions are in inches.
All dimensions tolerance $\pm 1/2"$.

MECHANICAL SPECIFICATIONS AND FEATURES

RANGE

The model SSCD is available in sizes from 30 to 300 tons and features HFC-407C refrigerant.

SCREW COMPRESSOR

- Separate refrigerant circuit for each compressor
- Semi-hermetic, horizontal screw type
- Two-pole hermetic motor
- Suction gas cooled motor
- Integral lubrication system using pressure differential
- Cast iron housing
- Infinite variable slide valve unloading
- Integral oil separator
- Compressor oil sump heaters



SHELL & TUBE EVAPORATOR

The adoption of a dedicated, high efficiency shell & tube heat exchanger allows us to increase cooling capacities by values close to 10%. This performance improvement can be alternatively translated into raising the evaporation temperature and in turn, optimizing the EER of the cooling system, not only in combination with R407C but also with the other refrigerants.

- Header tube sheet, shell, refrigerant and water connections are made of carbon steel
- High efficiency exchange tubes are in copper, internally finned.
- Baffles are made of brass or other suitable material (carbon steel)
- The bolt system is made of steel alloys or stainless steel depending on working conditions and temperatures, while gaskets are made of an asbestos free compound.



MECHANICAL SPECIFICATIONS AND FEATURES cont'd

CONDENSER COIL

- Constructed from staggered rows of inner ridged copper tubes, mechanically expanded into die-formed aluminum fins for positive bonding and efficient Heat rejection
- The pre-coated Aluminium fins improve corrosion resistance and maintain the fin surface for efficient heat of rejection
- The condenser coil is pressure tested up to 450psig with dry nitrogen under water for leaks
- Optional copper fins condenser coil

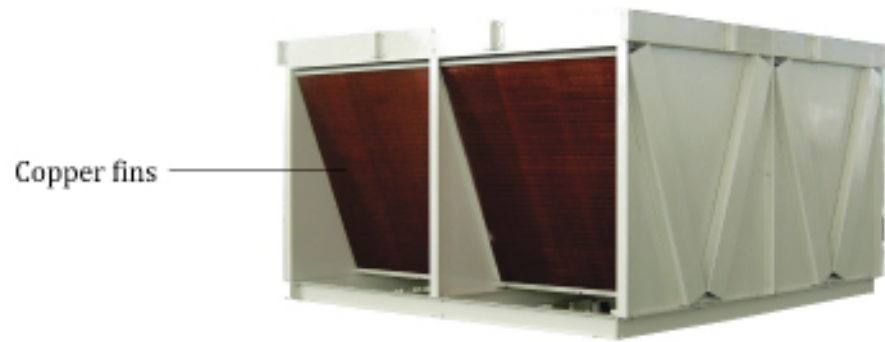

AXIAL PROPELLER FANS

- The patented and unique designed axial propellers are selected to deliver high condenser air flow rates, with ultra-low noise levels and low motor power consumption
- The 3-phase, totally enclosed air over, high starting torque, direct drive condenser fan motor runs at maximum speed of 1140 rpm
- All condenser fan motors are provided with either internal line break motor protection or external mounted overload protector; and suitable for outdoor installations with minimum IP54 protection
- Optional variable fan speed control or fan cycling in response to condensing head pressure, during low ambient condition

REFRIGERATION SPECIALTIES

- Thermal expansion valve(s)
- Sight glass with moisture indicator(s)
- Liquid line solenoid valve(s)
- Liquid line shut off valve(s)
- Removable core filter/drier(s)
- Charging and gauge connections
- Compressor discharge check valve(s) and stop valve(s)
- Compressor suction stop valve(s)
- High pressure relief valve(s)
- Refrigerant charge
- Oil charge



DIMENSION DATA

SSCD30-6 AR7

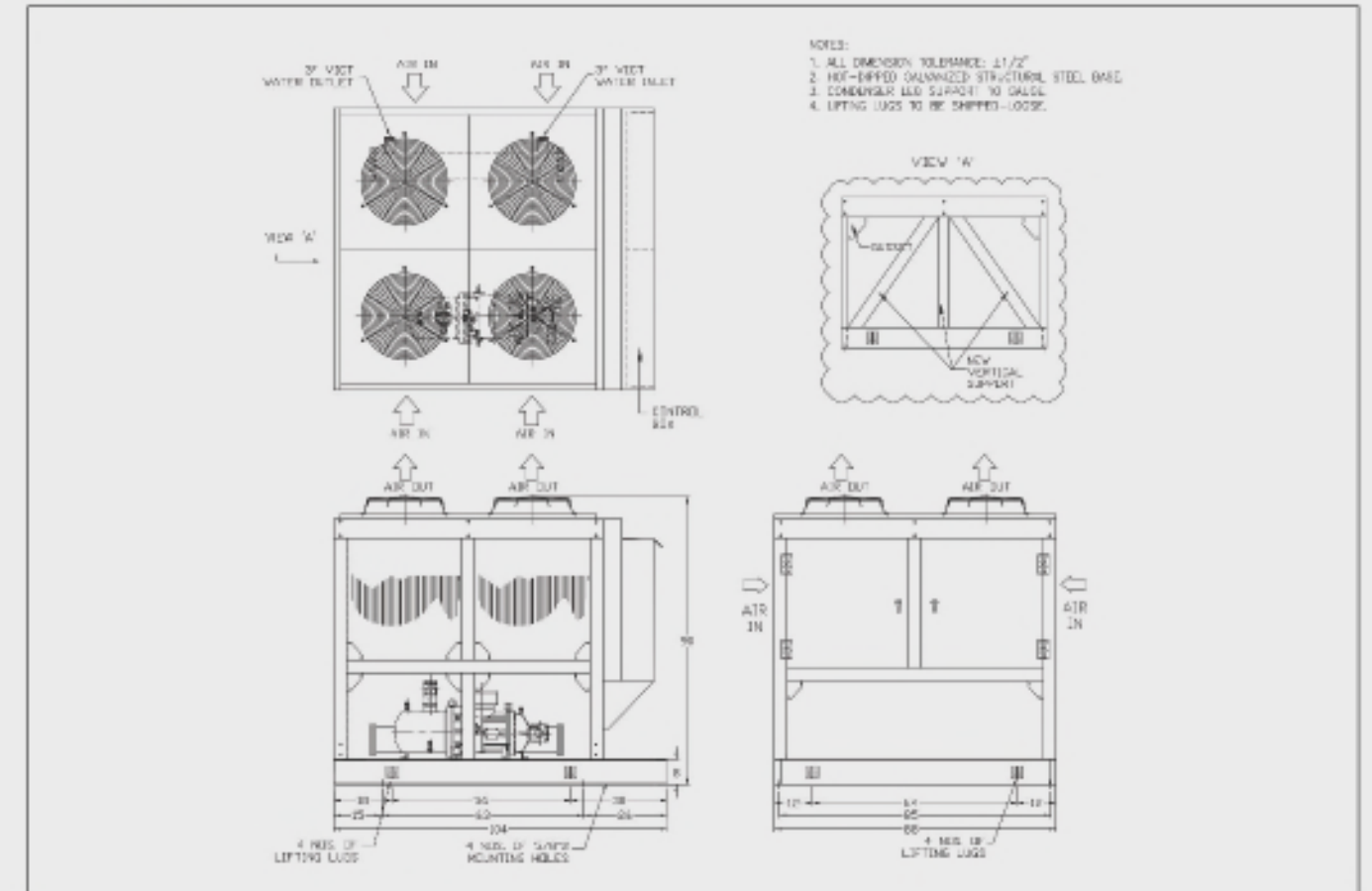

SSCD50-6 AR7

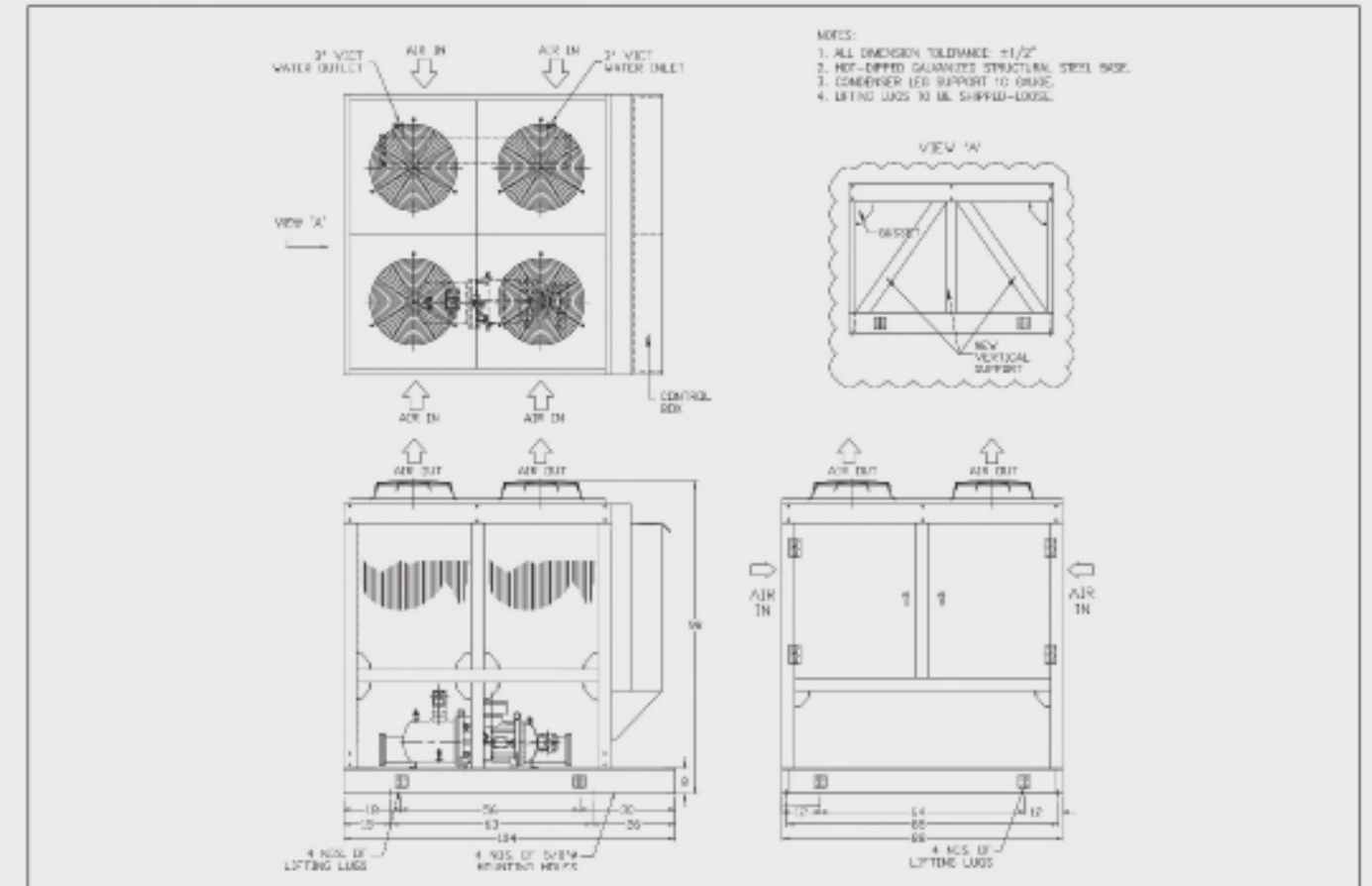

Note: All dimensions are in inches.
 All dimensions tolerance $\pm 1/2"$.

Sound Pressure Air-Cooled Chiller Package (60Hz) SSCD30-300AR7

SOUND LEVEL DATA

Sept 29, 2012
Rev. 0

Sound Pressure	Chillers Range									
	SSCD30AR7	SSCD50AR7	SSCD60AR7	SSCD80AR7	SSCD100AR7	SSCD125AR7	SSCD150AR7	SSCD210AR7	SSCD250AR7	SSCD320AR7
63	57.9	57.9	59.6	59.6	60.7	61.6	62.2	63.2	63.6	63.6
125	52.0	52.0	53.6	53.6	54.7	55.6	56.3	57.3	57.7	57.7
250	53.1	53.2	54.8	54.8	55.9	57.0	57.6	58.8	59.1	59.3
500	54.0	54.0	55.7	55.7	56.8	57.7	58.4	59.4	59.8	59.9
1k	54.1	54.1	55.7	55.8	56.9	57.9	58.5	59.6	59.9	60.1
2k	52.2	52.4	54.0	54.0	55.2	56.4	57.0	58.2	58.5	58.9
4k	51.1	51.2	52.8	52.8	53.9	55.0	55.6	56.7	57.0	57.2
8k	43.0	43.0	44.6	44.6	45.8	46.6	47.3	48.3	48.7	48.7
Total (Lp) dB	62.6	62.6	64.2	64.3	65.4	66.3	67.0	68.1	68.4	68.5
Low Noise Condenser Fans	63	30.8	32.2	33.6	34.9	37.8	38.3	40.0	40.0	41.6
	125	34.7	35.6	37.1	37.5	38.4	40.7	42.9	43.0	44.3
	250	41.6	42.7	44.0	44.4	45.4	48.1	48.7	50.4	51.9
	500	42.2	42.7	44.2	44.4	45.5	47.3	47.9	49.4	50.4
	1k	45.8	46.2	47.7	47.9	49.0	50.6	51.2	52.6	53.6
2k	46.3	46.9	48.4	48.6	49.6	51.7	52.3	53.9	53.9	55.0
4k	40.5	41.3	42.7	43.1	44.0	46.4	47.0	48.6	48.6	49.9
8k	32.6	32.8	34.4	34.5	35.5	36.7	37.3	38.4	38.8	39.1
Total (Lp) dB	51.1	51.7	53.2	53.4	54.5	56.5	57.1	58.7	58.7	59.8

Remarks:

*Sound pressure level (Lp) calculated in dB at 10m distance free field, ± 4 dB tolerance.

*Please consult factory for ratings at different distance/locations.



Smart Advance 2

The SmartAdvance2 is a rugged microprocessor based controller designed specifically for the hostile environment of the HVAC/R industry. It is designed with the most critical process and has customers in mind. The SmartAdvance2 provides flexibility with set points and control options that can be selected prior to commissioning a system or when the unit is live and functioning. Displays, alarms and other interfaces are accomplished in a clear and simple language that informs the user as to the status of the controller.

The SmartAdvance2 consists of a master micro controller along with a keypad and display. Complementing the SmartAdvance2 micro controller are a variety of expansion boards that allow for system expansion to a maximum of 48 inputs and 48 outputs. Communication to these units occur at 38,400 baud over the I/O port which is dedicated for this purpose.

Two other communication ports (RS-485 and Ethernet) are available on the SmartAdvance2. The RS-485 port allows the user to interactively communicate with the SMART Advance 2 via a Windows based connection software or, for monitoring purposes only, to a BMS (Building Management System) running Modbus RTU or Johnson N2. The Ethernet port allows the user to interactively communicate with the SmartAdvance2 via a Windows based connection software or, for monitoring purposes only, to a BMS running BACnet IP or Modbus IP. For LonTalk or BACnet MSTP communication, an external adapter is required.

OPTIONAL ACCESSORIES

Heat Recovery / Desuperheaters

This can be factory supplied and installed to get free hot water up to as high as 55°C.

Other Optional Accessories

- Coated or uncoated copper fins coils in lieu of pre-coated aluminium fins coils.
- Suction and discharge pressure gauges.
- Water flow switch to be shipped loose.
- Spring isolators to be shipped loose.
- Rubber-in-shear isolator to be shipped loose.



Pump/Tank Station

A process pump package can be integrated with or without a tank station. These tanks are offered in all 304SS or HDPE material - fully insulated with high-quality foam insulation. Pumps are available up to 15HP with 304SS and up to 60HP in other materials of construction. In tank sizes up to 1000 gallons, this section will be integral to the chiller skid and within a framed enclosure with rain shield. Above 1000 gallons, the tank section will be a separate skid.

POWER AND CONTROL PANEL

Each chiller is packaged with a power and control panel which is ready to accept rated 3 phase 60Hz electrical supply from a remote mounted isolator.

The power panel is furnished with factory pre-wired and mounted DOL starters for compressors, DOL starters for condenser fan motors. MCBs for compressors and fan motors, external overload protectors for compressors and/or fan motors. Power, alarm and compressor run lights to indicate unit operation status.

The Heart of the control panel is the highly reliable Smart-Advance SA600 microprocessor based controller with advance compressor management logic for scroll compressors in response to required chilled water inlet set-point temperature.

Under Voltage & Phase Protection Relay Included!

This protects against low incoming voltage conditions as well as single phase unbalance by opening the control circuit. This device will help to prolong the life of all of the motors on the package.

PERFORMANCE TABLE



Avg Water Temp. °F	Model SSCD	Ambient Temp. °F					
		85.0		95.0		105.0	
		Ton	KW	Ton	KW	Ton	KW
40	30	28.4	28.0	26.0	31.3	23.2	34.9
	50	47.0	48.5	42.5	54.2	37.5	60.3
	60	56.2	58.0	51.1	65.0	45.5	72.2
	80	74.7	76.0	68.0	85.0	60.5	94.6
	100	97.5	94.4	89.0	105.6	79.0	117.6
	125	112.6	106.0	103.1	118.4	92.0	131.8
	150	144.5	140.6	132.0	157.0	117.2	175.0
	210	199.6	203.2	180.9	227.0	158.9	252.8
250	236.8	246.9	213.6	275.7	186.6	306.3	
320	292.2	318.0	261.7	354.9	228.3	394.5	
42	30	29.6	28.2	27.2	31.5	24.3	35.2
	50	49.1	48.9	44.5	54.6	39.5	60.7
	60	58.8	58.6	53.6	65.4	47.8	72.8
	80	78.1	76.6	71.4	85.6	63.5	95.4
	100	101.8	95.2	93.2	106.4	83.1	118.4
	125	117.6	106.8	107.9	119.2	96.6	132.8
	150	151.0	141.8	138.2	158.2	123.2	176.4
	210	208.7	204.8	189.6	228.8	167.3	254.6
250	247.9	248.7	224.1	277.5	196.6	308.7	
320	305.8	320.4	274.9	357.6	240.8	397.2	
44	30	30.9	28.5	30.3	31.8	25.5	35.4
	50	51.3	49.3	50.0	55.0	41.5	61.2
	60	61.4	59.0	60.6	65.8	50.2	73.4
	80	81.5	77.2	80.0	86.2	66.7	96.0
	100	106.3	96.0	100.0	107.2	87.2	119.2
	125	122.8	107.6	120.0	120.2	101.3	133.8
	150	157.6	142.8	150.5	159.4	129.3	177.6
	210	218.2	206.4	207.0	230.4	175.9	256.4
250	259.2	250.8	245.0	279.6	207.0	310.8	
320	319.9	322.8	309.0	360.3	253.6	400.2	
46	30	32.3	28.7	29.7	32.0	26.8	35.7
	50	53.6	49.7	48.9	55.4	43.5	61.6
	60	64.1	59.6	58.8	66.4	52.7	74.0
	80	85.1	78.0	78.1	86.8	70.0	96.8
	100	111.0	96.8	101.9	108.0	91.5	120.2
	125	128.1	108.6	117.9	121.0	106.2	134.8
	150	164.5	144.0	151.1	160.6	135.6	179.0
	210	227.9	208.0	207.9	232.2	184.8	258.4
250	270.9	252.6	246.0	281.7	217.6	313.2	
320	334.4	325.5	303.2	362.7	266.9	403.2	
48	30	33.7	29.0	31.0	32.3	28.0	35.9
	50	55.9	50.1	51.2	55.8	45.7	62.1
	60	66.8	60.0	61.5	67.0	55.2	74.4
	80	88.8	78.6	81.6	87.6	73.3	97.4
	100	115.8	97.6	106.5	108.8	95.9	121.0
	125	133.6	109.6	123.2	122.0	111.2	135.8
	150	171.7	145.4	157.9	162.0	142.1	180.2
	210	238.0	209.8	217.5	234.0	194.0	260.2
250	283.0	254.7	257.4	283.8	228.5	315.6	
320	349.4	327.9	317.5	365.4	280.5	406.2	
50	30	35.1	29.2	32.4	32.6	29.3	36.2
	50	58.3	50.5	53.5	56.3	47.9	62.5
	60	69.7	60.6	64.2	67.4	57.8	75.0
	80	92.6	79.2	85.2	88.2	76.8	98.2
	100	120.8	98.6	111.3	109.6	100.4	122.0
	125	139.3	110.6	128.6	123.0	116.4	136.8
	150	179.0	146.6	164.9	163.2	148.8	181.6
	210	248.4	211.6	227.4	235.8	203.4	262.2
250	295.4	256.8	269.2	285.9	239.7	317.7	
320	364.8	330.6	332.2	368.4	294.5	409.2	

PHYSICAL SPECIFICATIONS

Model	SSCD 80 AR7	SSCD 90 AR7	SSCD 60 AR7	SSCD 80 AR7	SSCD 100 AR7	SSCD 125 AR7	SSCD 150 AR7	SSCD 210 AR7	SSCD 250 AR7	SSCD 320 AR7	
NOMINAL COOLING CAPACITY	RT	90.3	50.0	80.0	100.0	120.0	150.5	207.0	245.0	309.0	
EBP/PV	9.6/12.4	9.8/12.8	9.7/12.5	10.1/13	10.1/14.4	10.7/15.2	10.2/14.6	10.7/14.5	9.6/14	9.6/14	
TYPE	SEMI-HERMETIC SCREW										
COMPRESSOR	RPM	3550	3550	3550	3550	3550	3550	3550	3550	3550	
QUANTITY	1	1	2	2	2	2	2	2	3	3	
MIN. % UNIT CAPACITY REDUCTION	CONTINUOUS CAPACITY CONTROL										
TYPE	DIRECT EXPANSION SHELL & TUBE EVAPORATOR										
WATER FLOW RATE	USGPM	73	120	145	192	240	288	361	497	742	
WATER PRESSURE DROP	FT WG	16.1	10.1	17.9	17.0	18.5	16.4	18.0	15.5	16.4	
WATER CONNECTION	IN [MM]	5 [76]	4 [102]	4 [102]	6 [152]	6 [152]	6 [152]	8 [203]	8 [203]	8 [203]	
TYPE	HYDROPHILIC FIN TYPE										
COIL	PPI	14	14	14	14	14	14	14	13	14	
TOTAL FACE AREA	FT ²	102	107	160	160	213	267	307	440	440	
CONDENSER	CONDENSER FAN	DIRECT DRIVE PROPELLER FAN									
FAN MOTOR	HP	6.0	6.0	9.0	9.0	12.0	15.0	18.0	24.0	27.0	
QUANTITY	4	4	6	6	8	10	12	16	18	18	
AIR FLOW	CFM	55,200	56,000	84,000	72,880	128,160	145,040	192,880	225,600	221,640	
NOMINAL POWER SUPPLY	460 / 3 / 60										
ELECTRICAL	UNIT BLA	A	56.6	110.2	138.6	174.6	197.6	280.2	372.8	453.6	
UNIT MCA	A	68	111	122	154	193	288	413	487	604	
UNIT MFS	A	100	160	160	200	300	400	500	600	700	
UNIT DIMENSION	WIDTH [MM]	88 [2235]	88 [2235]	88 [2235]	88 [2235]	88 [2235]	88 [2235]	88 [2235]	88 [2235]	88 [2235]	
LENGTH [MM]	104 [2642]	104 [2642]	144 [3568]	144 [3568]	185 [4699]	224 [5690]	274 [6960]	356.5 [9055]	404 [10160]	400 [10160]	
HEIGHT [MM]	90 [2286]	98 [2489]	98 [2489]	98 [2489]	98 [2489]	98 [2489]	99 [2515]	99 [2515]	99 [2515]	99 [2515]	
APPROX. UNIT SHIPPING WEIGHT	LB [kg]	6041 / 2740	6283 / 2850	8874 / 4025	9111 / 4133	10582 / 4800	12170 / 5520	14043 / 6370	20018 / 9080	27822 / 12620	
APPROX. UNIT OPERATING WEIGHT	LB [kg]	6155 / 2792	6415 / 2910	8898 / 4077	9376 / 4255	10836 / 4915	14396 / 6530	20346 / 9129	28395 / 12879	38700 / 17618	
APPROX. REFRIGERANT CHARGE, R407C	LB [kg]	75 / 33	121 / 55	147 / 67	194 / 88	243 / 110	305 / 166	502 / 228	594 / 270	749 / 340	

Note: *Kw refers to compressor power input in KW

Note: All dimensions are in inches. All dimensions tolerance ±1/2".